

Zoo of Electric Circuits for Optimization Algorithms

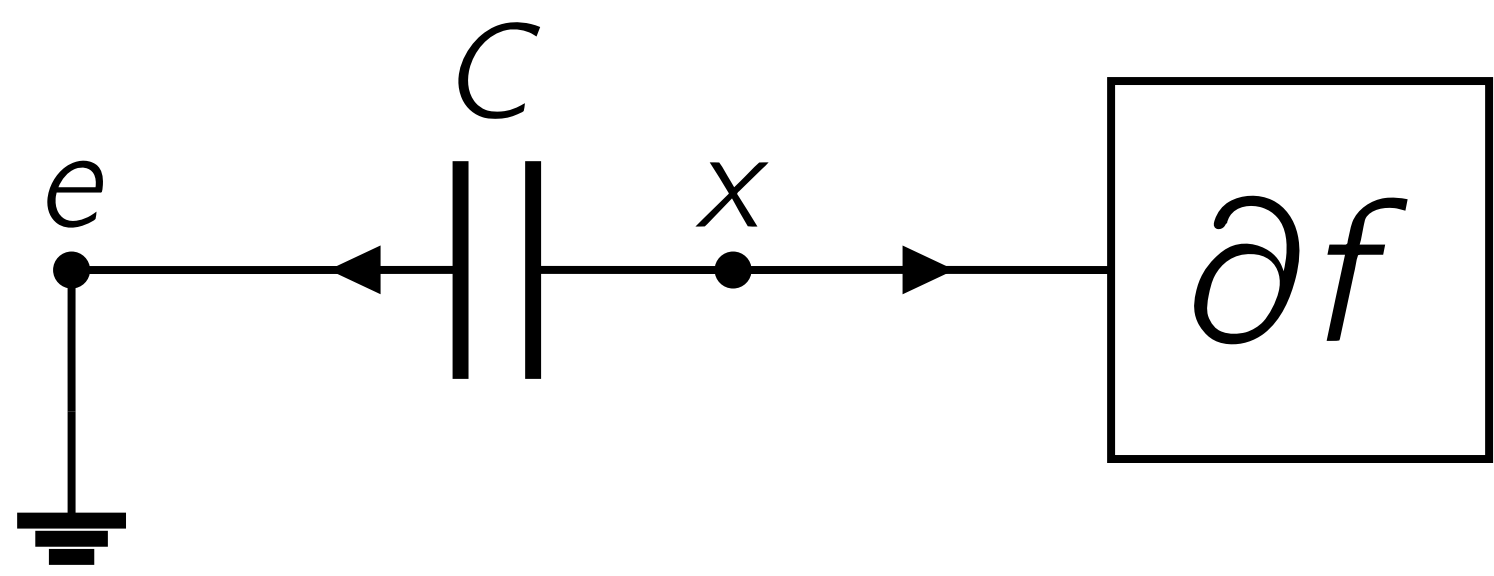

Gradient Descent



Primal Decomposition

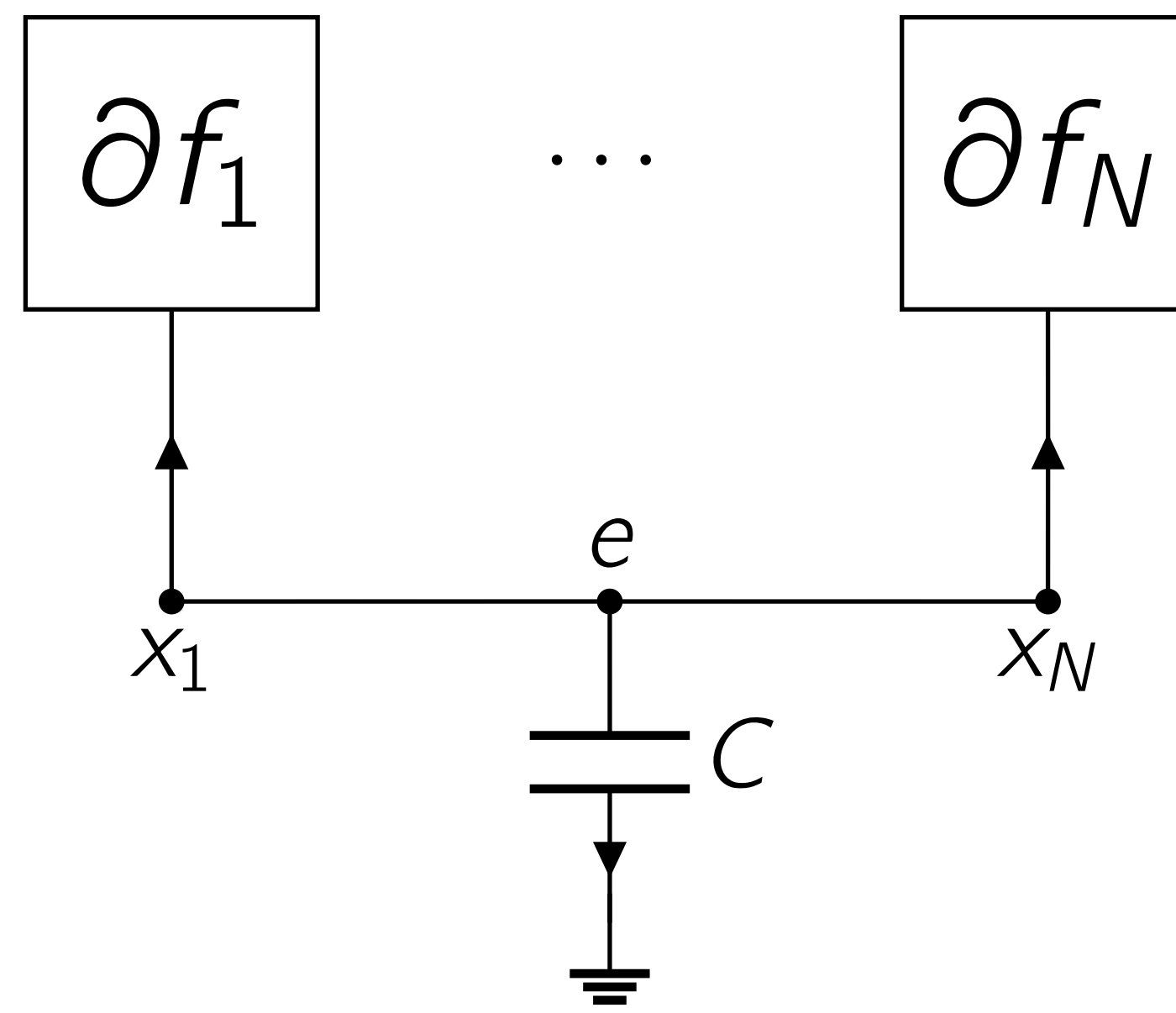

Decentralized GD

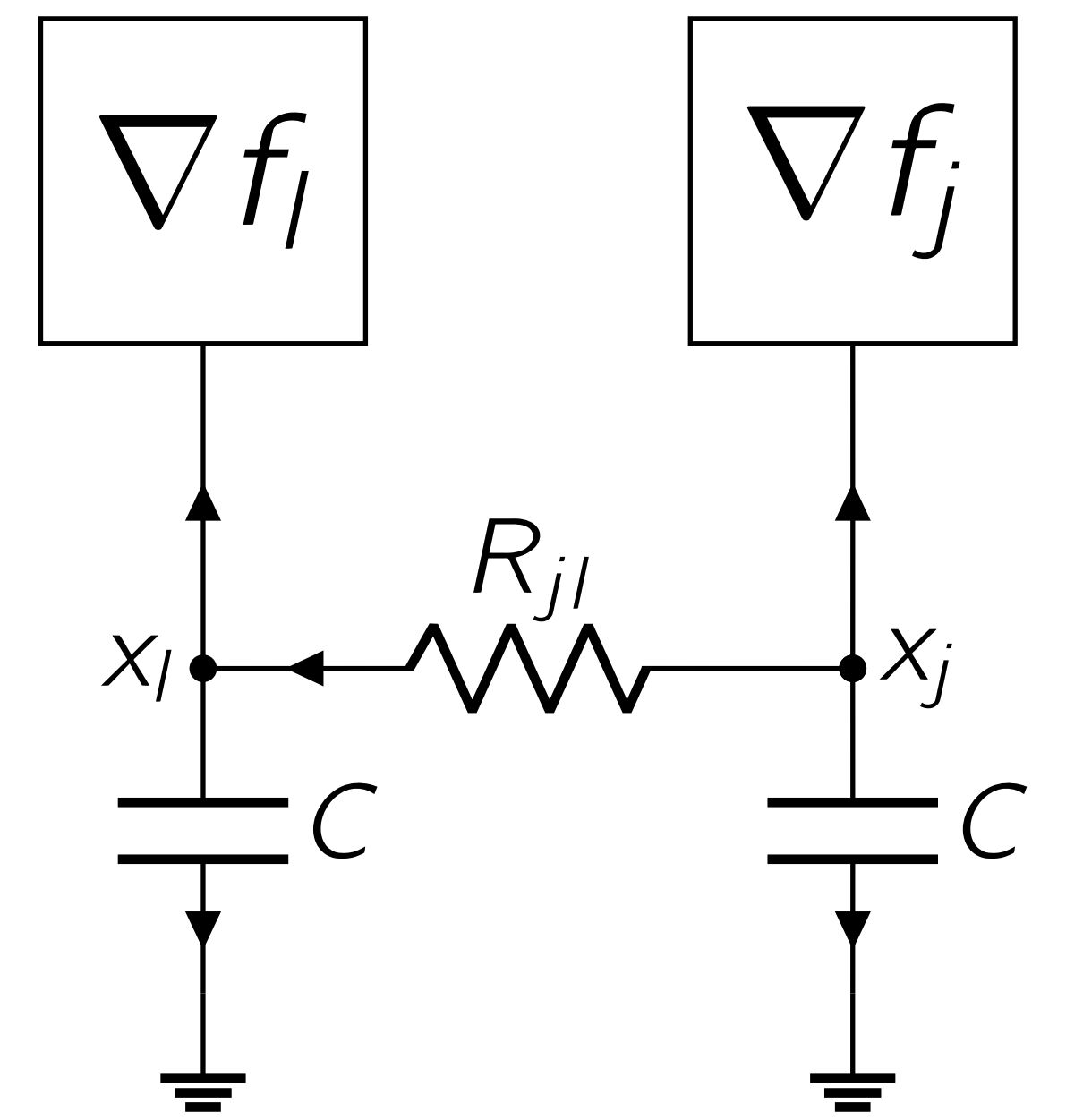

Nesterov acceleration

with $R = \sqrt{L/C}$

(Acceleration at critical damping)

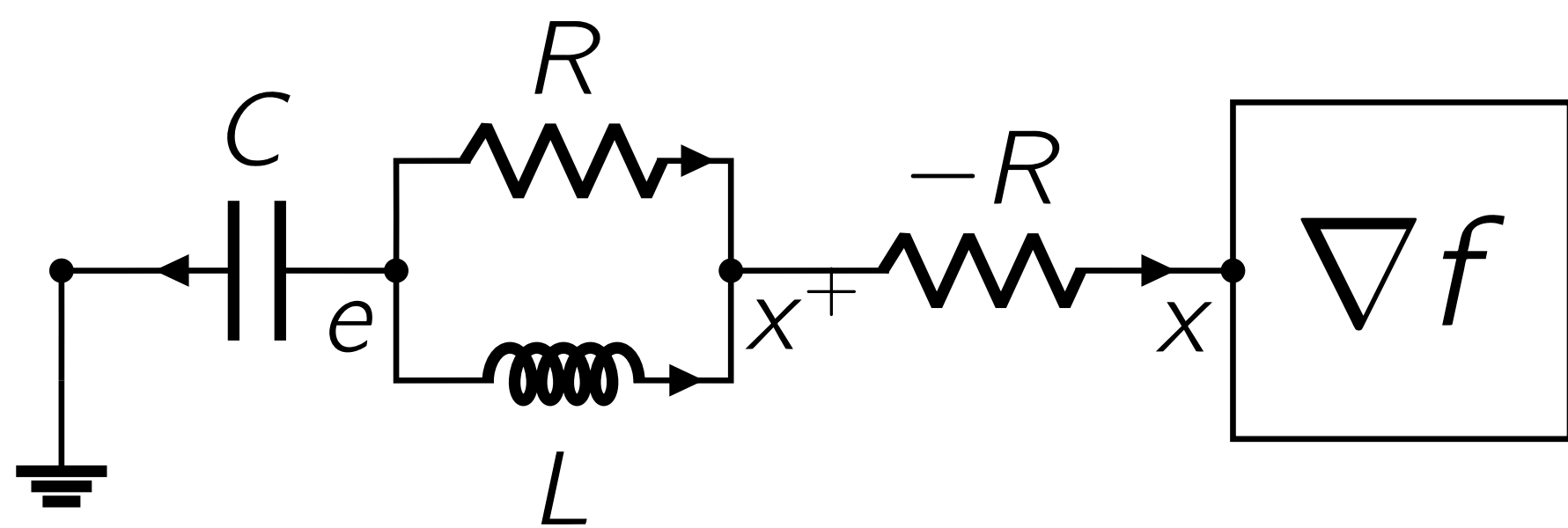

Dual Decomposition

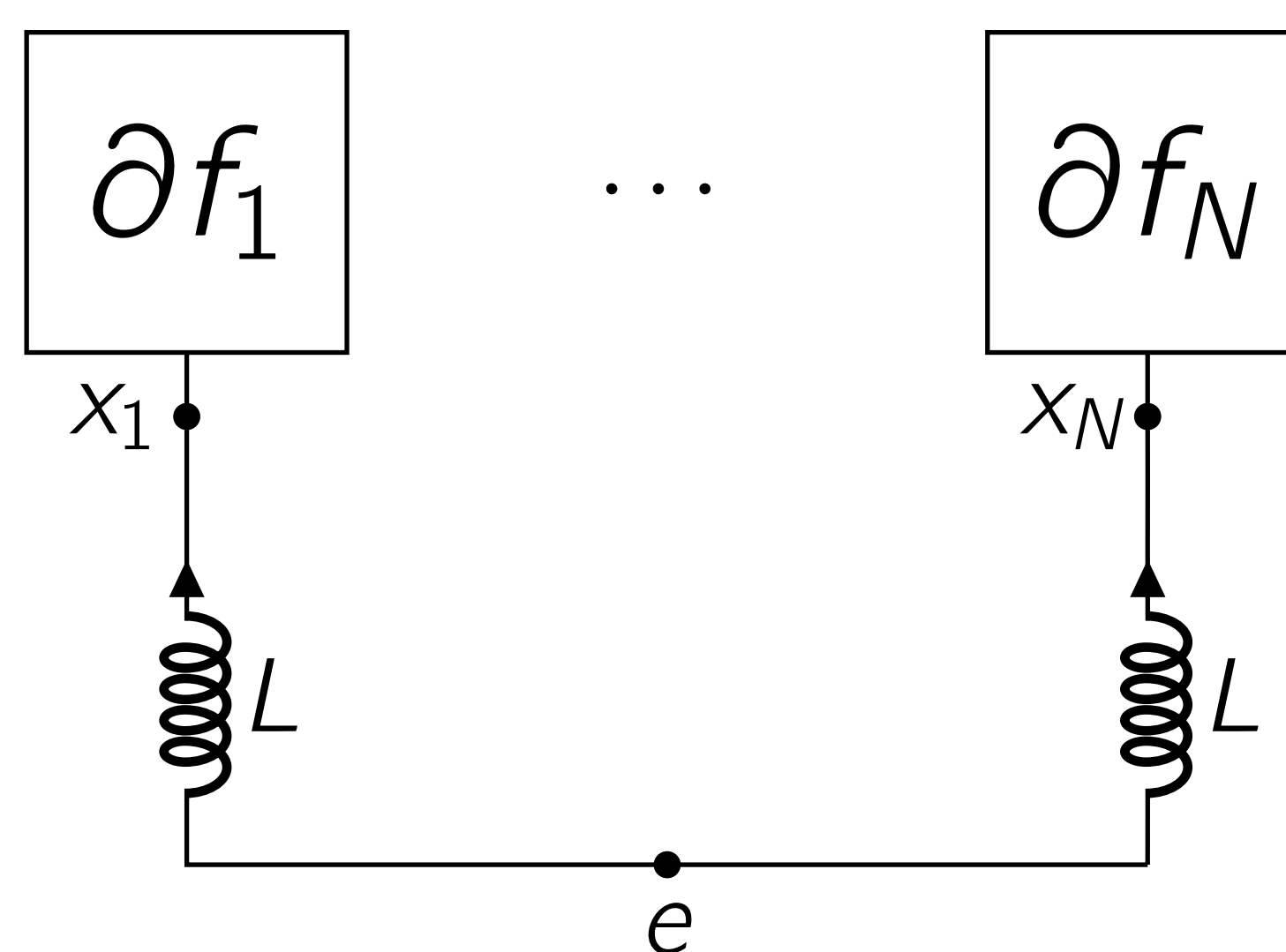

Adapt-then-combine

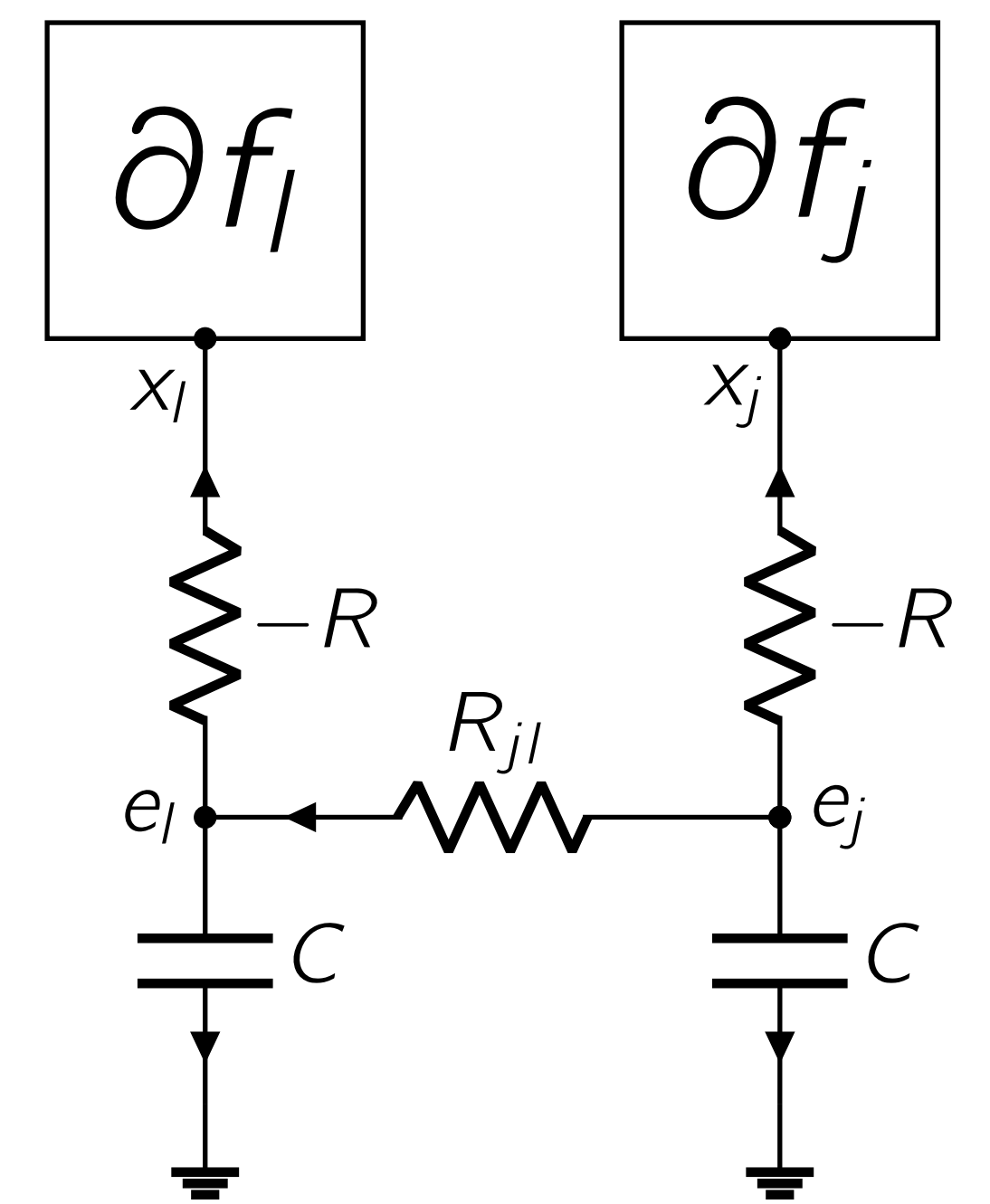

Proximal point method

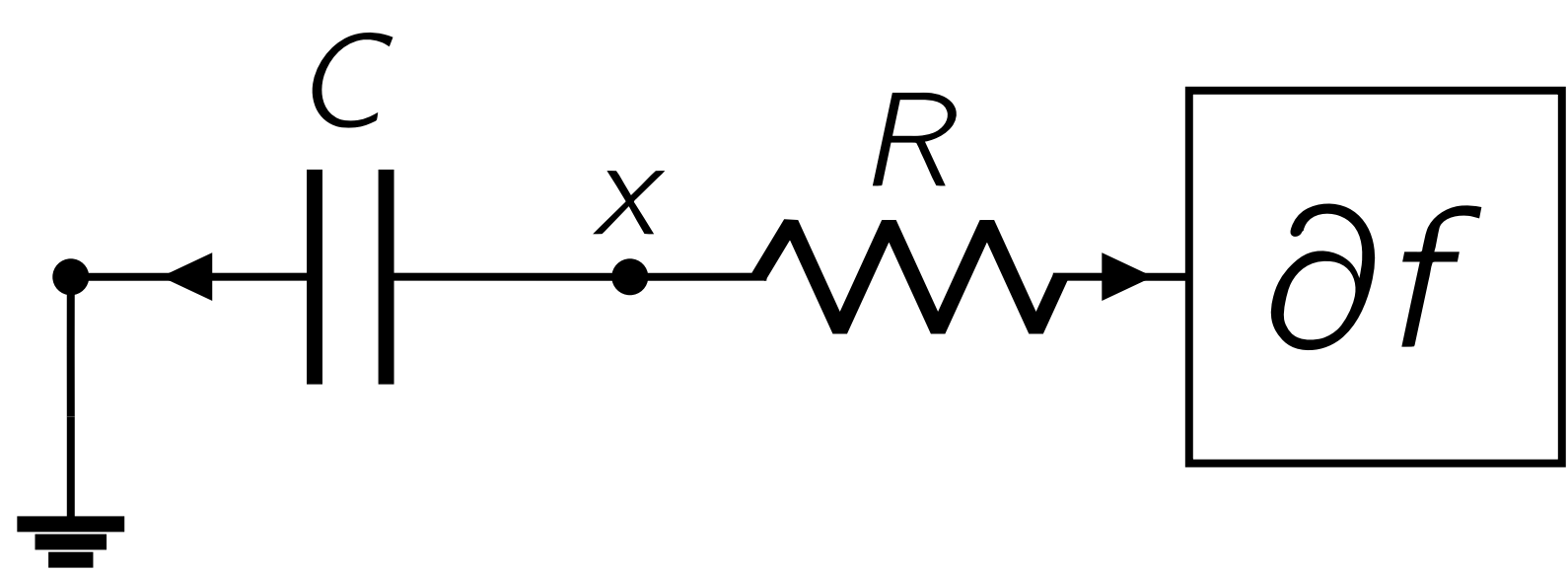

Prox Decomposition

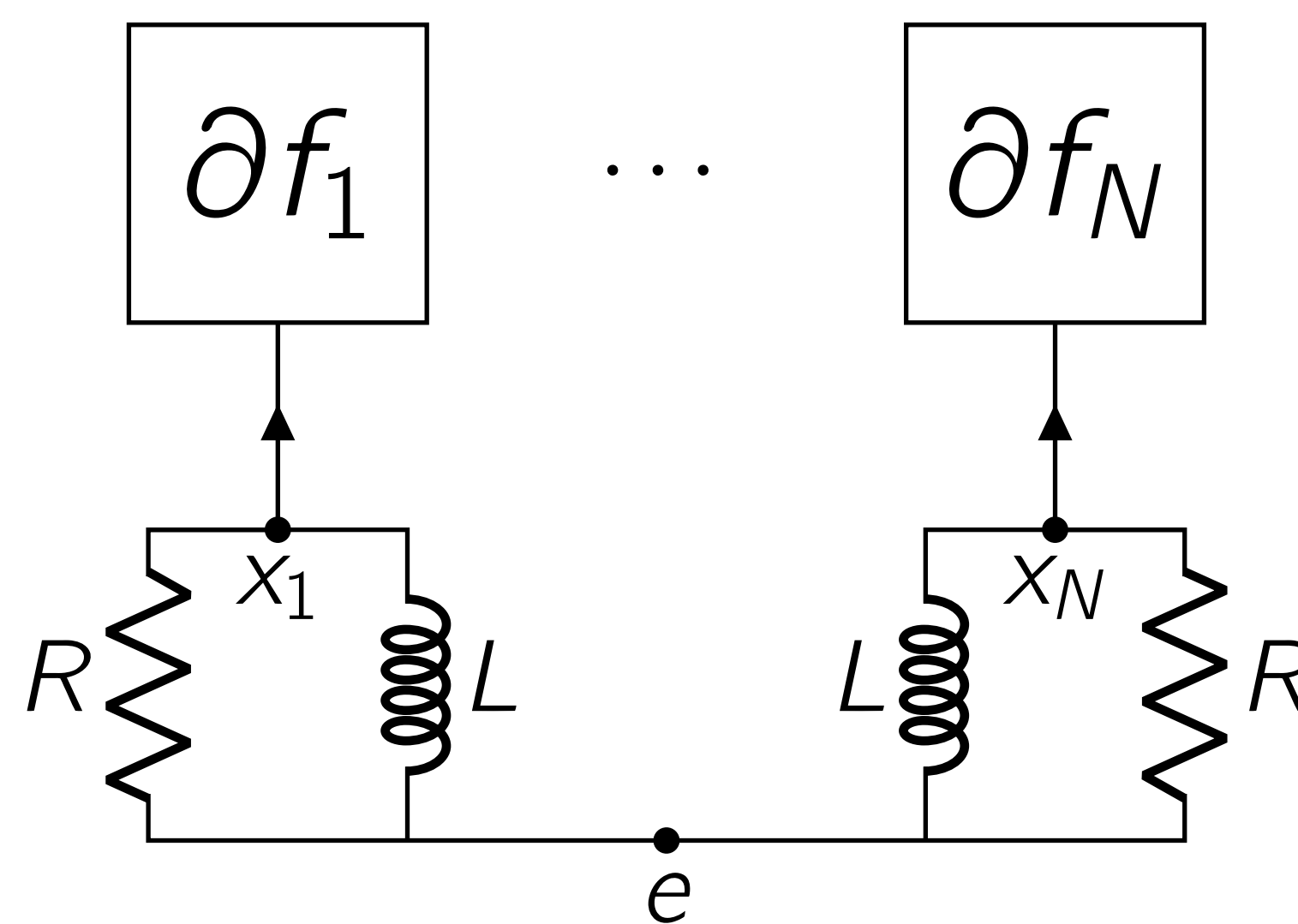

Decentralized ADMM

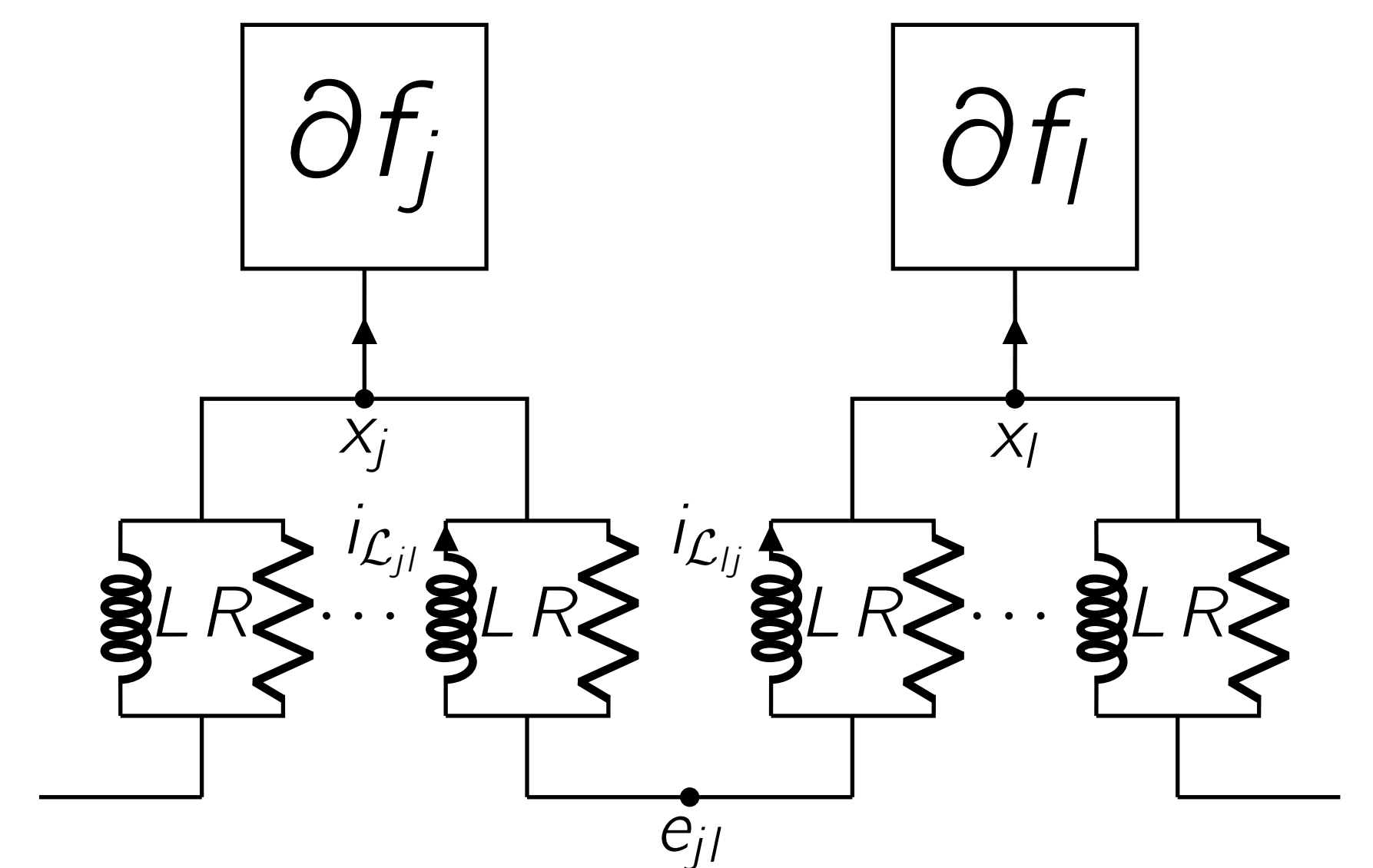

Prox-grad method

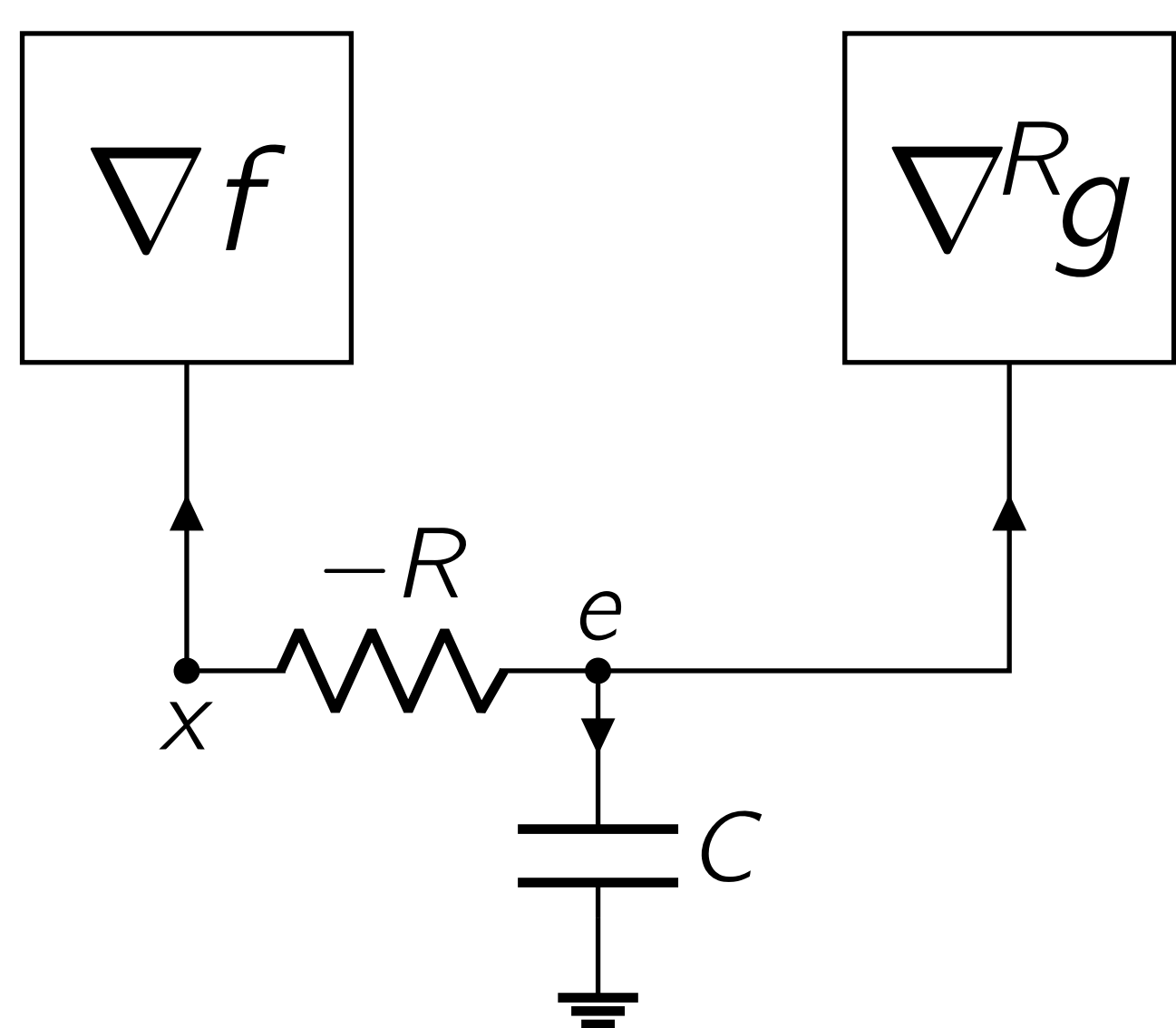

Douglas-Rachford splitting

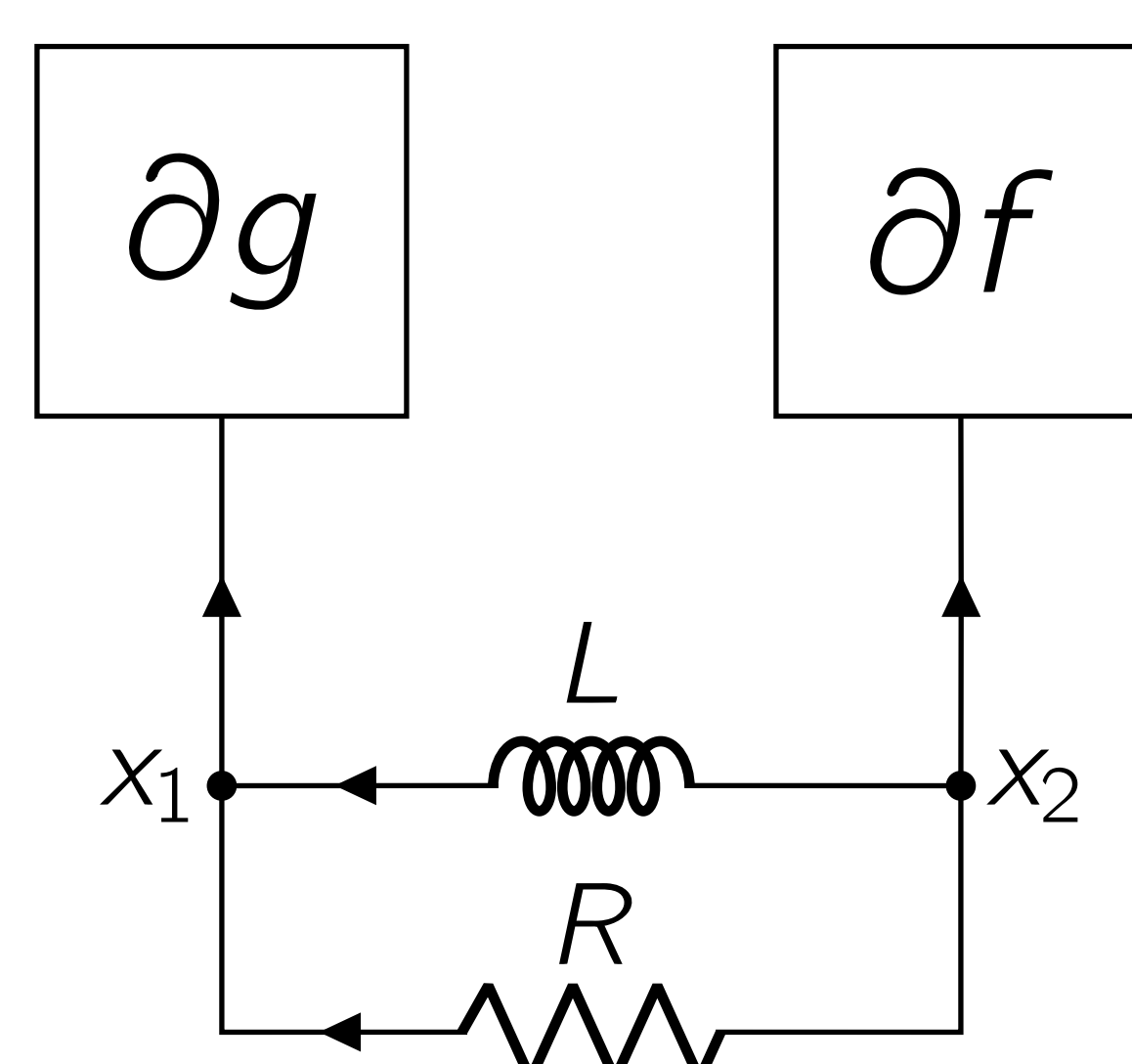

PG-EXTRA

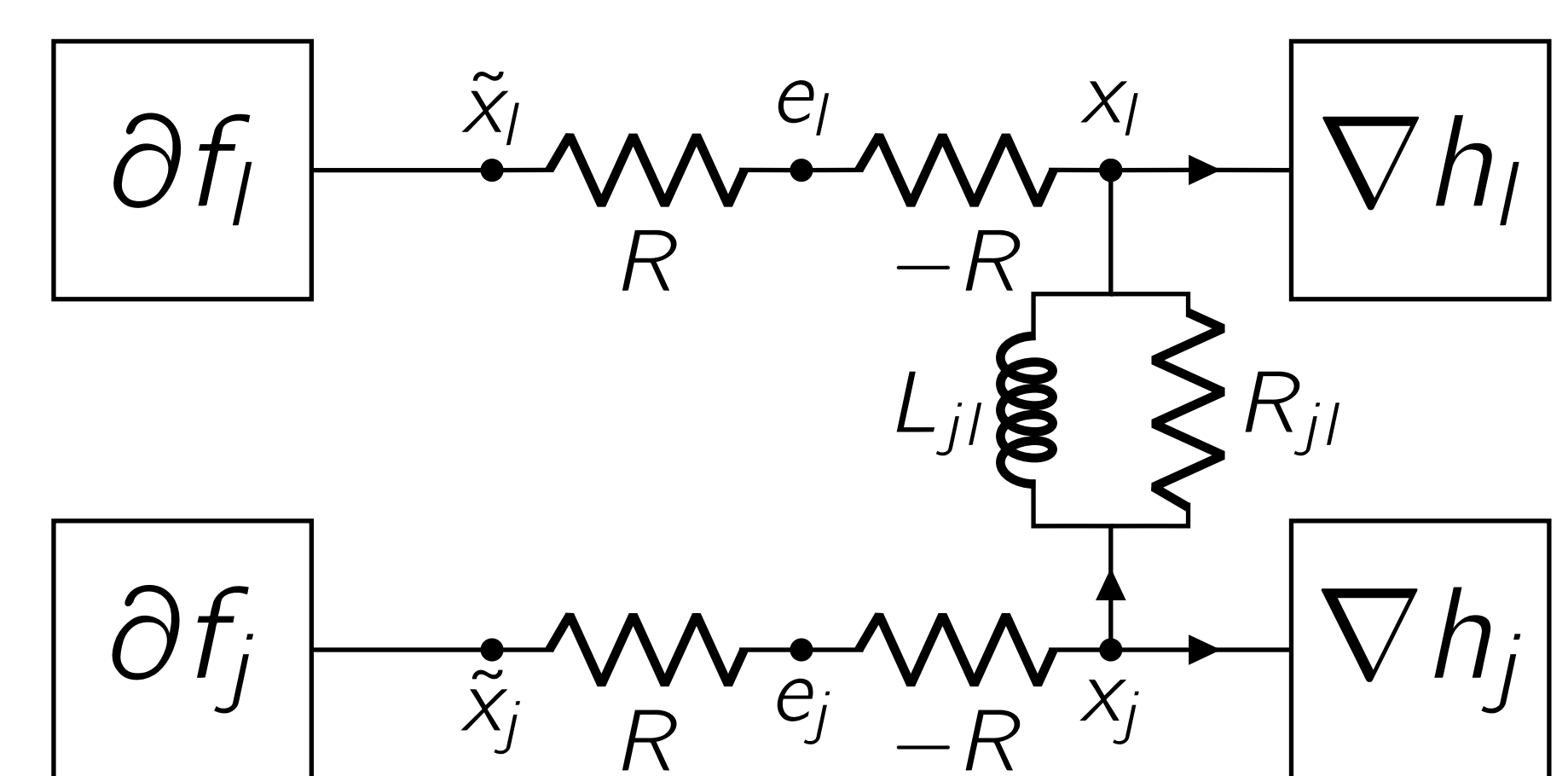

Your algorithm

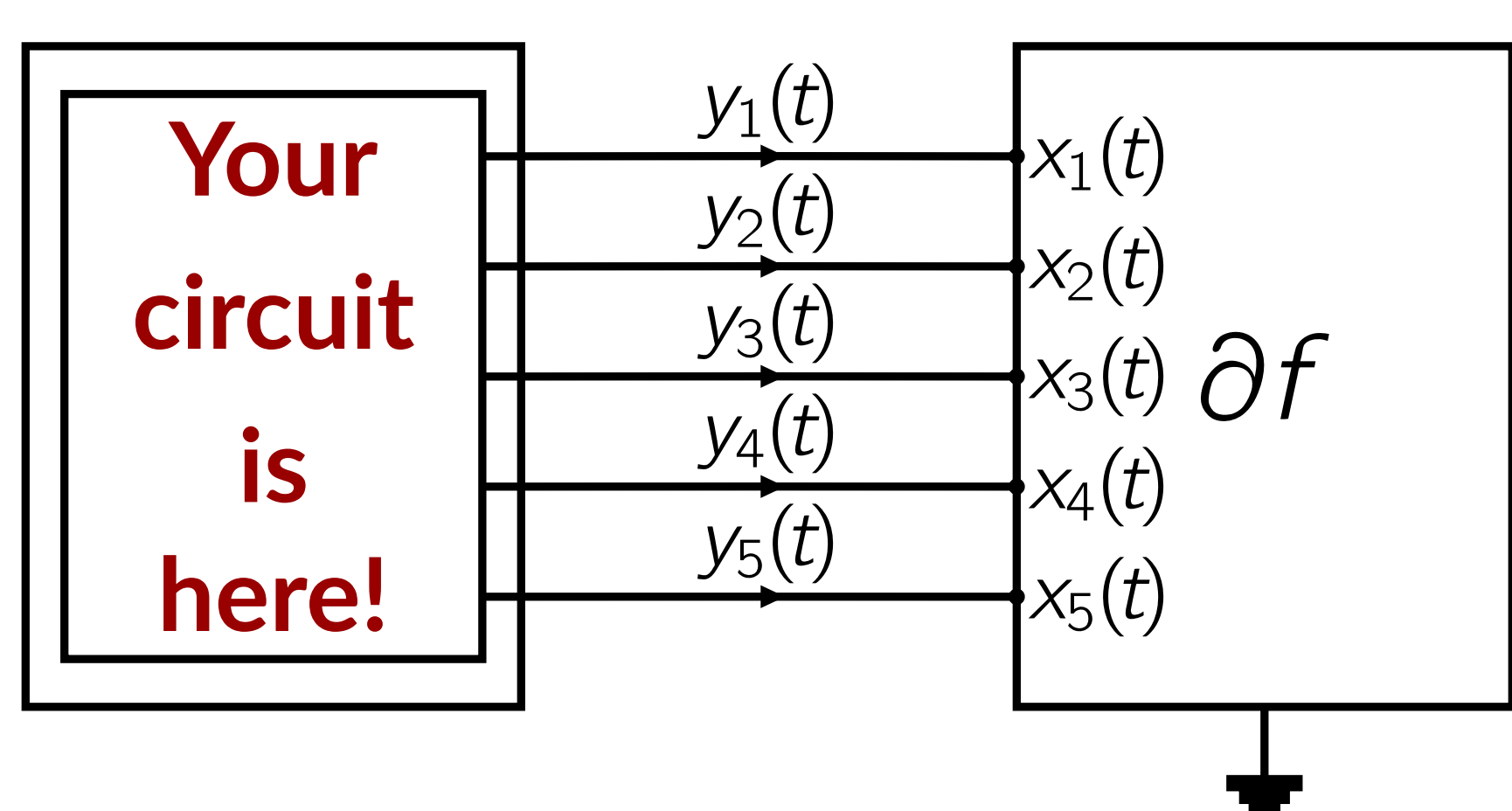

Davis-Yin splitting

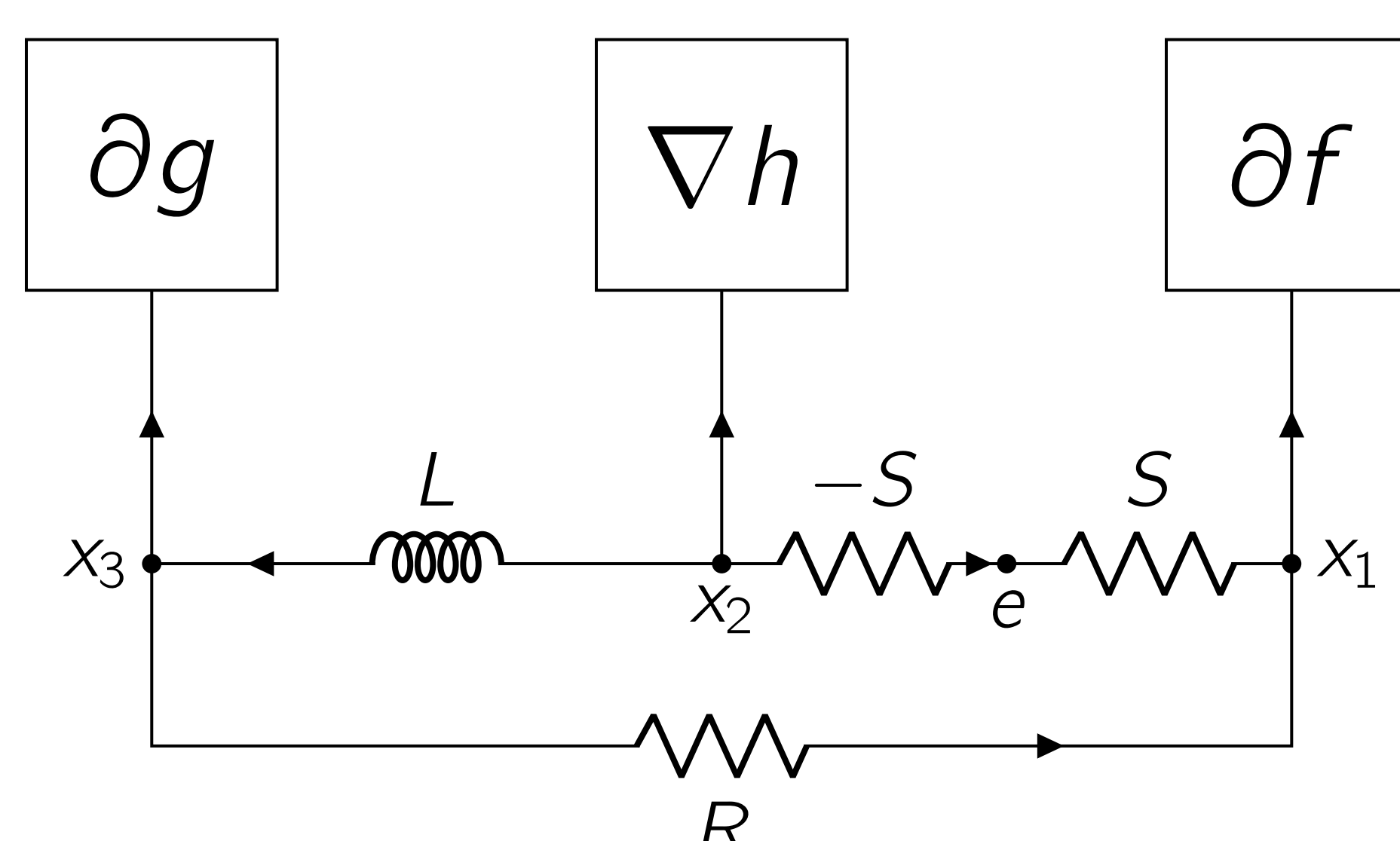

DADMM+C (new!)

